

# DACS-G-S015-22/23/24-SS/WP-I-S\*\*

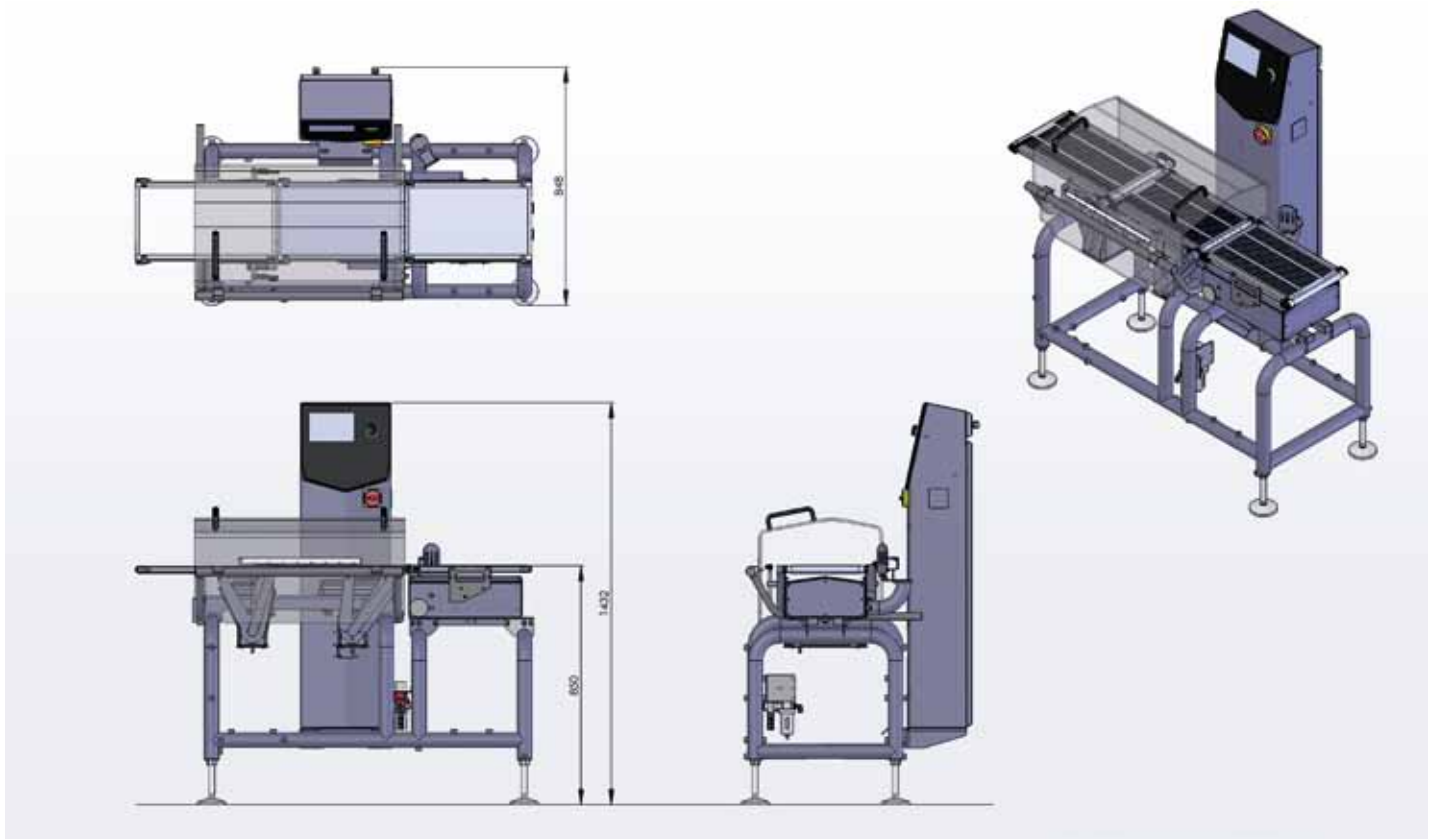

Ishida DACS Checkweighers offer you:

- Confidence that your products are always weight-compliant
- Help in maintaining and improving profitability\*
- State-of-the-art technology delivering optimum performance and value
- Consistent accuracy through robust, reliable design
- Low maintenance requirements and minimal cleaning downtime
- A wide range of models and options to suit your exact need and budget

\*Helping ensure your packs are legal is only one way in which checkweighers can protect or improve your profitability.

\*\*Offset Control Unit

DACS-G-S015-22/23/24-SS/WP-I-S		
Weighing range*	6 - 600g (multi range)	15 - 1500g (multi range)
Maximum accuracy*	±0.05g	±0.2g
Maximum speed*	400wpm	
Display	7" colour LCD, touch keypad, command dial	
Protection type	IP54 / IP65	
Temperature range	-5° - 40°C (RH 30-85% no condensation)	
Air requirements	0.4 MPa (4.1kgf/cm²) 8mm piping connection	
Line height	850 +/- 600mm	
Product Dimensions	Length	10 to 400mm
	Height	10 to 180mm (with windshield cover 130mm)
	Width	20 to 240mm
Power requirements	100 to 240 v AC 50/60Hz	
Conveyor width	240mm	
Infeed conveyor length	350, 450mm	
Weigh conveyor length	250, 350, 450mm	
Outfeed conveyor length	450mm	
Reject system**	Single air / heavy duty air / pneumatic arm	

